

# *The Gardeners Partner: Rain Barrels*

By Kurt Hoffman

You may be asking, why *Rain Barrels*? It seems like in today's environment we think we have plenty of everything! But do we?

Until the 1950's and 60's open water storage (rain barrels, cisterns) were common in most areas. But with the increase of municipal water systems, and a concern for public health and safety, they became a bit of nostalgia.

We are now looking for alternatives to conserve water due to the cost of and shortages in municipal water systems. Also, we are overstressing our storm water systems with the increase of hard surfaces (driveways, roads, patios, buildings). More water is running into storm sewers than ever before, and it is taking larger amounts of pollutants with it into our lakes and streams.

But today we have an opportunity to make use of this water resource. You can find most of the parts at hardware stores to make a rain barrel to safely collect rain water.

Before you shop for parts, consider these points:

1. The amount of runoff from your roof will determine if you need an overflow system.
2. The container should be clean and not have been used for anything hazardous (should have a HAZMAT rating of 0 or 1).
3. I recommend using a plastic container as it won't rust.
4. Screening is needed to exclude bugs, animals and debris.
5. The location of your rain barrel should make it easy to drain.
6. Rain barrels should be placed near the downspouts of your house, garage, or out-building, facing the direction where you want the

overflow to drain. You want it to drain away from the foundation, maybe towards a garden area or landscape plants.

7. Your rain barrel should be raised up at least 12-16 inches for easier draining. You can use a stack of cinder blocks/bricks, wood (as in the following instructions), or something else that will support the weight of a full barrel (approx. 400 lbs.).
8. You will need access to the spigot for your watering can or garden hose. This low pressure setup is also good for a drip irrigation system in garden beds.
9. To make your rain barrel aesthetically pleasing to you and your neighbors, decorate it with paint, hide it behind a shrub or trellis with vining plants, or place it out of sight behind a shed or other structure. Have fun and be a little whimsical in your decorating ideas.

Before you start your rain barrel project, please read the enclosed instructions fully, and look at the location of your rain barrel in relation to your gardens.





## Tools, Materials & Sources

### Tools

Jigsaw/Sabresaw  
 Drill  
 1 inch holesaw  
 Bi-metal jigsaw blade  
 Adjustable holesaw  
 Circular saw  
 #2 square drive or Phillips bits  
 Ruler or tape measure  
 Scissors  
 Utility knife  
 Dremel with sanding drum  
 Marker or pencil  
 5/16 socket driver  
 Screwdriver  
 Wrenches

### Materials

Clean plastic barrel  
 ¾ inch brass hose bib with T-handle  
 1½ inch sump pump hose kit  
 1½ inch PVC adapter  
 Hose clamps  
 ¾ inch galvanized nut or coupling  
 Exterior silicone caulk  
 #10x¾ or 1 inch self tapping screws  
 Flex hose downspout extension  
 Downspout straps and screws  
 1 4x4x8' treated  
 3 2x4x6' treated  
 1 5/4x6x6' treated decking  
 2½ inch decking screws  
 Window screening/aluminum or pet safe  
 Exterior paint and wood stain

### Sources for Barrels

Global Technologies  
 620 Hinkel Street  
 Green Bay, WI 54303  
 920-494-1620

Hydroclean Equipment  
 1900 Dickinson Road  
 De Pere, WI 54115  
 920-337-0109

## Barrel Set-up

- Rinse barrel thoroughly.
- Decide on the type of opening you would like on top of your barrel; it can be done in a variety of ways. Here are three ways to try:
  - Use a jigsaw to cut top off around outside of bungholes; which you then stretch screening over and secure with barrel lid ring.
  - Again as in part A., you cut around the bungholes. Then just under the rim you cut or drill a pilot hole; and cut off the rim with jigsaw. Stretch screening over opening and flip rim over; setting it on top of barrel and screening, securing with self tapping screws.
  - Mark out an area on top that leaves 1 ½ to 2 inches around edges; it should be 6 inches wide and 6 to 12 inches long. Also mark lines at 1 ½ inch intervals on the 6 inch side so you have 4 strips marked. Drill a pilot hole in one or two of the corners that you marked, use a jigsaw to cut inside the lines. Take the cut-out piece and carefully cut apart the strips into 4 separate pieces. Cut a piece of screening 2 inches wider and longer than opening. Put a bead of caulk around the opening and lay the screening over it. Lay the center 2 strip on long sides of opening, over screening, secure with self tapping screws. Take outer 2 strips and trim to fit on the ends of the opening, securing with self tapping screws.
- Use 1 inch holesaw to make an opening 3 to 4 inches above bottom of barrel for hose bib.
- 3-4 inches from top rim of barrel, about 90 degrees from the first hole, trace an outline of 1½ inch PVC adapter.
- Use adjustable holesaw to drill out marked area or drill a pilot hole with 1 inch holesaw to insert jigsaw blade and cut inside marked area.
- Screw in ¾ inch hose bib in the hole made for it towards the base; may secure the back with a nut or coupling. Caulk the threads as you screw it in and around it on the inside and out when done.

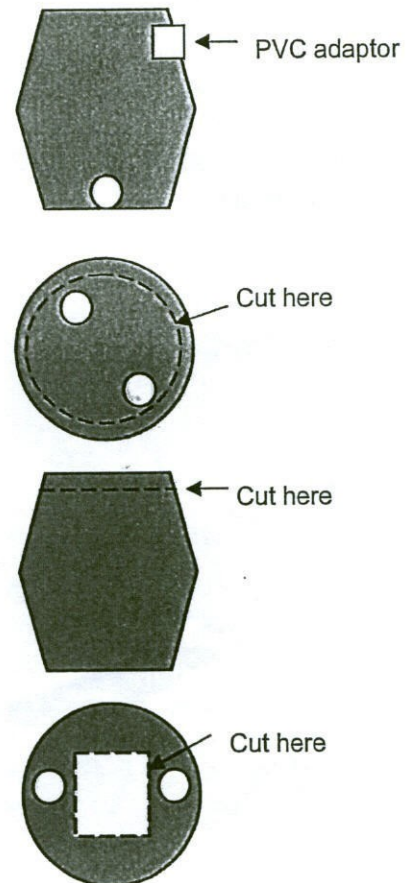

*Continued on next page...*



## Barrel Set-up (continued)

- Screw in 1½ inch PVC adapter; you may have to use the dremel; with sanding drum, to widen opening. Caulk around the adapter.
- Let caulk dry; then either paint barrels or install them near downspouts.

**Note:** Joining together two or more barrels; you will need another PVC adapter for each barrel. Make opening for PVC adapter and follow steps 4 and 5. Use a length of sump pump hose and hose clamps to connect them.

## Barrel Stands

- Cut 4x4x8' into 4 pieces 16 inches long; and two pieces 12½ inches long for double stand.
- Cut 2x4x6' into 3 pieces 22 inches, 2 pieces 20 inches, 2 pieces 36 inches; to make a double stand.
- Cut 5/4x6x8' decking into 4 pieces 22 inches.
- Attach 1 of the 2x4x22 to 2 of the 4x4x16 with deck screws. Make 2 sets like that.
- Using the 2x4x20 inch pieces connect the two sets together.
- Attach 1 of the 2x4x22 to the 4x4x12½. Then attach the 2x4x36 to 4x4x12½, and then to first assemble.
- Lay 5/4x6x22 decking on outer top edges and attach with screws.

**Note:** Stands can be made from a variety of items, such as cinderblocks or bricks. Make sure the area where the stand is to be placed is level and the ground is firm; may place pavers or gravel under stand for stability.

## Installation

- Level ground where you want to place barrels.
- Place stands and barrels in place to determine at what height to cut downspout to divert towards top of barrels.
- Cut out a section of downspout and attach flex extension to upper part and secure downspout to house with straps. Stretch the flex extension over the top of barrel.
- Attach 1 1/2-inch sump pump hose to 1 1/2-inch PVC adapter and secure with hose clamps.

Stand: Top View

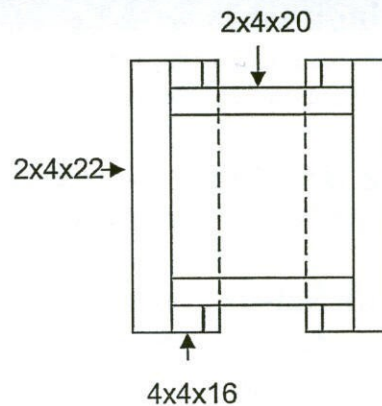

Double Stand: Side View

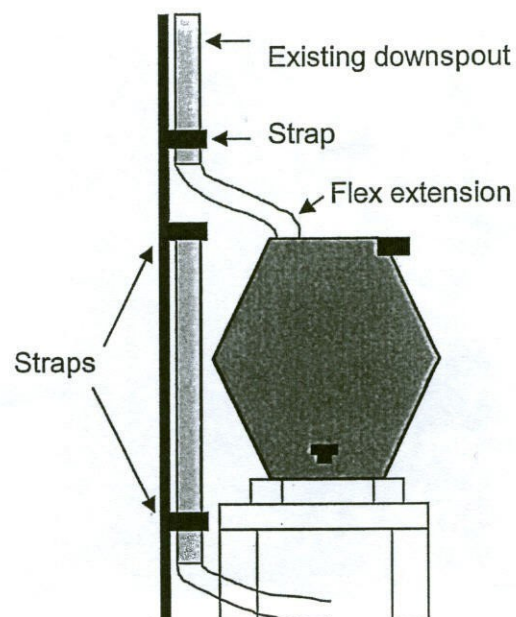
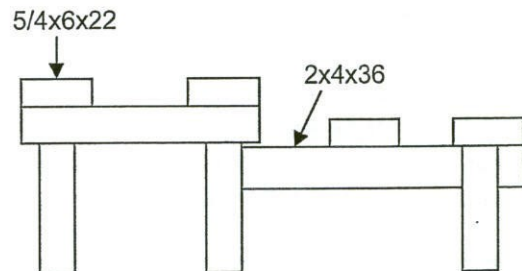



---

## Caring for Your Rain Barrel

**Winterizing:** Empty barrels and leave spigot open. If left in place, turn over or cover top with a board or other rigid material to protect screening and keep them empty. Make sure to secure it against wind by tying it down or placing in a safe place. Connect flex extension to rest of downspout to bypass barrel and direct water away from house.

**Screening Overflow:** Cover the overflow with a piece of screening and a hose clamp to secure it; either on the end of the hose or inside the barrel on the 1½ inch connector.

**Springtime Set-up:** Check over barrels to make sure caulk around spigot is still good; replace, if necessary. Look at screening for holes or openings and replace or repair. Place near downspouts on a stand at least 12 to 16 inches off of ground, and divert downspout to barrels. Connect the sump pump hose to overflow and point it away from foundation of house.

**Cleaning:** To clean the exterior of barrels use a mild soap and rinse thoroughly before painting. Clean the interior using bleach or ammonia with water; rinse well before use.

**Painting:** Use a plastic paint found at most hardware or home stores (available in a spray can and brush-on type). Most have a 7-day period to adhere to plastic, but are dry to the touch and you are able to paint over it in just 24 hours.

**Decorating:** If you prefer, when installing your rain barrels you can place a trellis and some climbing plants or shrubs next to them (but leave yourself access to the spigot), so they are hidden from view. Make sure to have a foot or two between barrels and planting to allow for air flow and access.

---

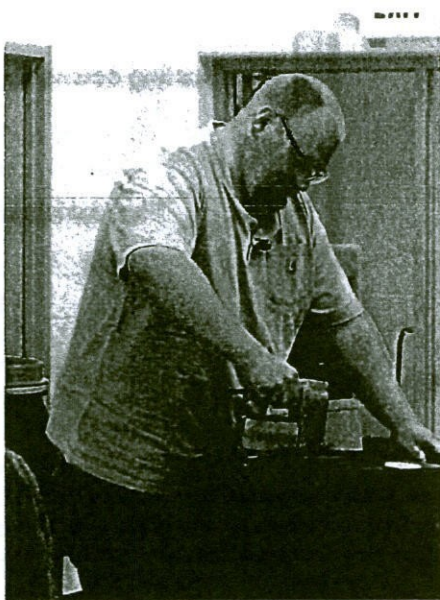

### The Gardeners Partner: Rain Barrels

Kurt Hoffman  
450 Bosar Avenue, Green Bay, WI 54304  
Phone: 920-435-4429 or 920-431-0292  
Email: Kurthoffm@aol.com

This publication was written by Kurt Hoffman, Green Bay, WI.

Drawings and layout were produced by Linda L. Blondin, Brown County UW-Extension Horticulture Department, Green Bay, WI. UW-Extension provides equal opportunities in employment and programming including Title IX & ADA.

**UW**  
**Extension**